

Instruction Manual

READ CAREFULLY BEFORE USE
THE EQUIPMENT

Ref. AT 011-W
EN 795:2012 / B



Safety Tripod TM 9-W

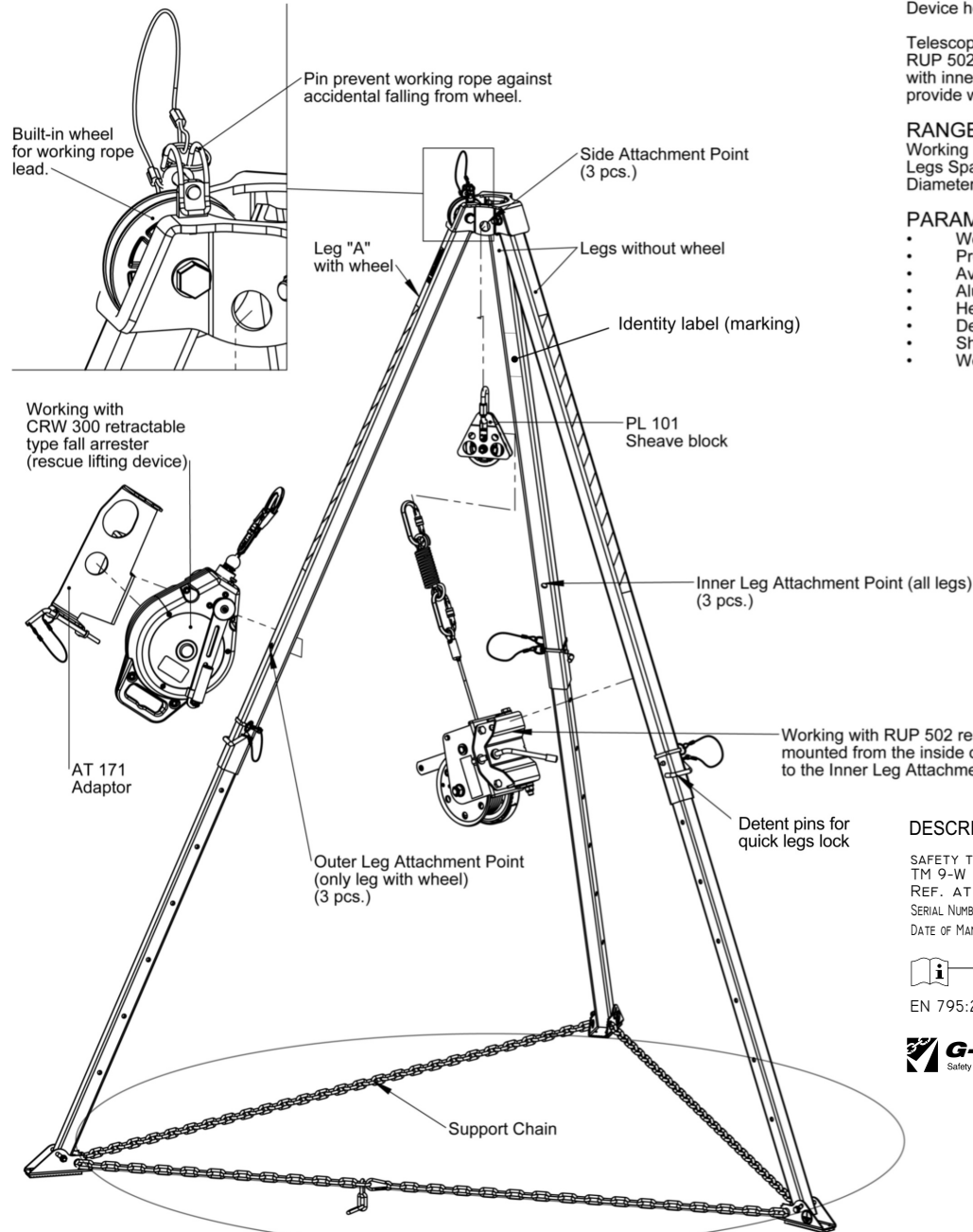

DESCRIPTION

Safety tripod TM 9-W is a component of personal protective equipment against fall from height. It is used as portable anchor point. Safety tripod TM 9-W has to be used in conjunction with fall arrest equipment.

Safety tripod TM 9-W has been tested according to EN 795 as a temporary anchorage device class B.

Safety tripod TM 9-W provides protection for maximum one person at the same time.

Device head is equipped with one wheel provides rope guidance when RUP 502 or CRW 300+AT 171 devices are used.

Telescopic legs allow to adjust tripod's height (7 positions). "A" leg (with wheel) is equipped with outer and inner Leg Attachment Points for using with RUP 502 rescue lifting device or with CRW 300 retractable type fall arrester (with additional Adaptor - AT 171). Two legs without wheel are equipped with inner Leg Attachment Points for using with RUP 502 rescue lifting device mounted from the inside of the tripod (PL 101 sheave block is needed to provide working rope lead).

RANGES (legs fully retracted...extended)

Working Height : 147...229 cm
Legs Spacing : 110...171 cm
Diameter over which it can deploy a tripod : 127...200 cm

PARAMETERS

- Working Load Limit: depends on using equipment,
- Protection for maximum two people at the same time,
- Available 6 Attachment Points,
- Aluminium alloy legs,
- Head with built-in wheel for working rope lead,
- Designed to use with: RUP 502 / CRW 300+AT 171 rescue lifting devices,
- Shipping dimensions: 175 x 23 x 23 cm,
- Weight (with chain): 21,8 kg.

DESCRIPTION OF MARKING

SAFETY TRIPØD _____ type of device
TM 9-W _____ reference number
REF. AT 11-W _____ serial number of device
SERIAL NUMBER: 00003 _____ production month/year
DATE OF MANUFACTURE: MM/YYYY _____
 notice: read the instruction manual before use
EN 795:2012/B _____ European standard (number/year/type)
 marking of producer or distributor

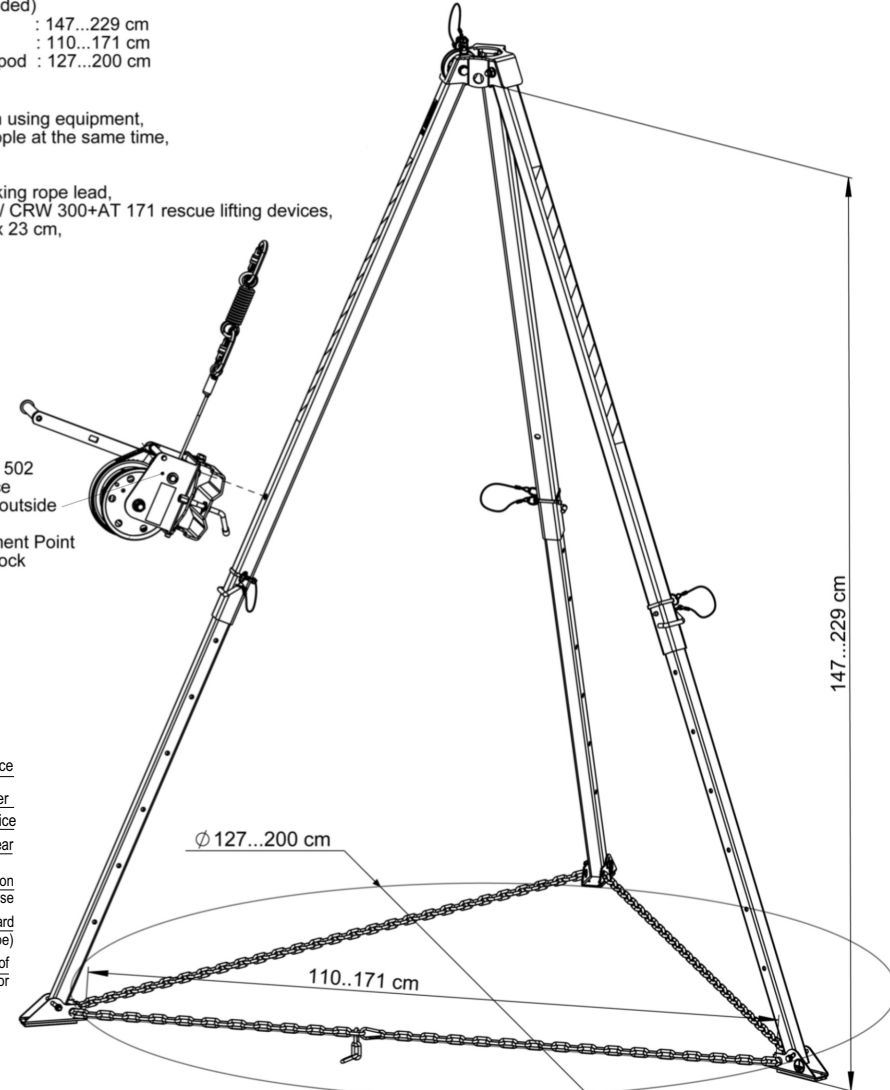

INSTALLING A TRIPOD

- Place the tripod on a flat, stable and hard surface. Pull out the tripod legs to the desired length and lock with the locking pin.

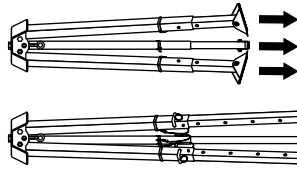

- Set the tripod in an upright position and fully spread the legs.
- Make sure the feet are on firm ground and can support the load.
- Adjust the length of the legs so that the head is located in the horizontal plane.
- The legs must always have the same length.
- The tripod should be positioned over opening so working line will be located approximately in the center of the opening

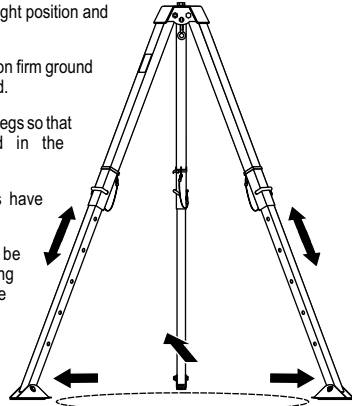

- Make sure the locking pins are properly secured the end of the locking pin must protrude above the surface of the tripod legs.
- Secure the tripod legs with the chain against the accidental sliding open. The ends of the chain must be fastened with a snap hook. The chain should be tight between the legs of the tripod. Remove excess slack of the chain. Instead of the chain the special webbing (supplied with the tripod) can be used.

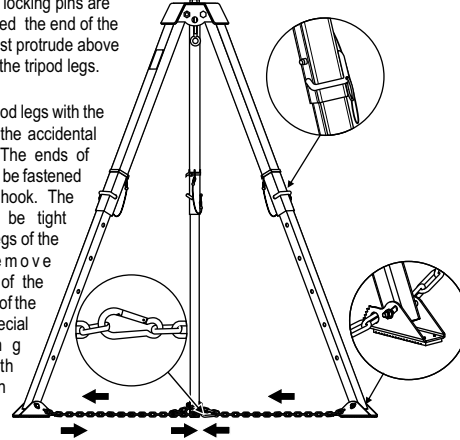

- !While working, pay attention to the chain, which fastens the tripod legs, as it can cause accidental tripping of the worker!
- The tripod must never be used without the leg chain (or the webbing) in place
- Avoid working where the user may swing and hit an object or where lines may cross or tangle with that of another worker in the area.
- To collapse tripod, pull leg down and swing leg in.

Fall arrest and rescue systems used with this tripod must meet applicable EN standard requirements:

- EN 795 - for anchor devices
- EN 353-2 - for guidet type fall arresters
- EN 362 - for connectors
- EN 1496 - for rescue lifting devices
- EN 361 - for full body harnesses
- EN 1497 - for rescue harnesses
- EN 360 - for retractable type fall arresters
- EN 341 - for descender devices

WITHDRAWAL FROM USE AFTER ARRESTING A FALL

Safety tripod TM 9-W must be withdrawn from use immediately when it have been used to arrest a fall. After that must be carried out detailed manufacturer's inspection of the tripod.

The manufacturer's inspection can be carried out by:

- manufacturer
- or person recommended by manufacturer
- or company recommended by manufacturer.

During this inspection will be established if the tripod can be longer used and will be defined the admissible time of tripod use till next manufacturer's inspection.

ADMISSIBLE TIME OF USE

The tripod can be used for 5 years counting from a date of putting the tripod into operation. After this period the tripod must be withdrawn from use to carry out manufacturer's detailed inspection.

The manufacturer's inspection can be carried out by:

- manufacturer
- or person recommended by manufacturer
- or company recommended by manufacturer.

During this inspection will be established admissible time of tripod use till next manufacturer's inspection.

THE ESSENTIAL PRINCIPLES FOR USERS OF PERSONAL PROTECTIVE EQUIPMENT AGAINST FALLS FROM A HEIGHT

- personal protective equipment shall only be used by a person trained and competent in its safe use.
- personal protective equipment must not be used by a person with medical condition that could affect the safety of the equipment user in normal and emergency use.
- a rescue plan shall be in place to deal with any emergencies that could arise during the work.
- it is forbidden to make any alterations or additions to the equipment without the manufacturer's prior written consent.
- any repair shall only be carried out by equipment manufacturer or his certified representative.
- personal protective equipment shall not be used outside its limitations, or for any purpose other than that for which it is intended.
- personal protective equipment should be a personal issue item.
- before use ensure about the compatibility of items of equipment assembled into a fall arrest system. Periodically check connecting and adjusting of the equipment components to avoid accidental loosening or disconnecting of the components.
- it is forbidden to use combinations of items of equipment in which the safe function of any one item is affected by or interferes with the safe function of another.
- before each use of personal protective equipment it is obligatory to carry out a pre-use check of the equipment, to ensure that it is in a serviceable condition and operates correctly before it is used.

- during pre-use check it is necessary to inspect all elements of the equipment in respect of any damages, excessive wear, corrosion, abrasion, cutting or incorrect acting, especially take into consideration:
 - in full body harnesses and belts - buckles, adjusting elements, attaching points, webbings, seams, loops;
 - in energy absorbers - attaching loops, webbing, seams, casing, connectors;
 - in textile lanyards or lifelines or guidelines - rope, loops, thimbles, connectors, adjusting element, splices;
 - in steel lanyards or lifelines or guidelines - cable, wires, clips, ferrules, loops, thimbles, connectors, adjusting elements;
 - in retractable fall arresters - cable or webbing, retractor and brake proper acting, casing, energy absorber, connector;
 - in guided type fall arresters - body of the fall arrester, sliding function, locking gear acting, rivets and screws, connector, energy absorber;
 - in connectors - main body, rivets, gate, locking gear acting.
 - in tripods - legs, safety pins, eye bolts, feet, chain, connecting elements.
- after every 12 months of utilization, personal protective equipment must be withdrawn from use to carry out periodical detailed inspection. The periodic inspection must be carried out by a competent person for periodic inspection. The periodic inspection can be carried out also by the manufacturer or his authorized representative. In case of some types of the complex equipment e.g. some types of retractable fall arresters the annual inspection can be carried out only by the manufacturer or his authorized representative.
- regular periodic inspections are the essential for equipment maintenance and the safety of the users which depends upon the continued efficiency and durability of the equipment.
- during periodic inspection it is necessary to check the legibility of the equipment marking.
- it is essential for the safety of the user that if the product is re-sold outside the original country of destination the reseller shall provide instructions for use, for maintenance, for periodic examination and for repair in language of the country in which the product is to be used.
- personal protective equipment must be withdrawn from use immediately when any doubt arise about its condition for safe use and not used again until confirmed in writing by equipment manufacturer or his representative after carried out the detailed inspection.
- a full body harness (conforming EN 361) is the only acceptable body holding device that can be used in a fall arrest system.
- in full body harness use only attaching points marked with big letter "A" to attach a fall arrest system.
- the anchor device or anchor point for the fall arrest system should always be positioned, and the work carried out in such a way, as to minimise both the potential for falls and potential fall distance. The anchor device/point should be placed above the position of the user. The shape and construction of the anchor device/point shall not allowed to self-facing disconnection of the equipment. Minimal static strength of the anchor device/point is 12 kN. It is recommended to use certified and marked structural anchor point complied with EN795.
- it is obligatory to verify the free space required beneath the user at the workplace before each occasion of use the fall arrest system, so that, in the case of a fall, there will be no collision with the ground or other obstacle in the fall path. The required value of the free space should be taken from instruction manual of used equipment.
- there are many hazards that may affect the performance of the equipment and corresponding safety precautions that have to be observed during equipment utilization, especially:
 - trailing or looping of lanyards or lifelines over sharp edges,
 - any defects like cutting, abrasion, corrosion,
 - climatic exposure,
 - pendulum falls,
 - extremes of temperature,
 - chemical reagents,
 - electrical conductivity.
- personal protective equipment must be transported in the package (e.g.: bag made of moisture-proof textile or foil bag or cases made of steel or plastic) to protect it against damage or moisture.
- the equipment can be cleaned without causing adverse effect on the materials in the manufacture of the equipment. For textile products use mild detergents for delicate fabrics, wash by hand or in a machine and rinse in water. Plastic parts can be cleaned only with water. When the equipment becomes wet, either from being in use or when due cleaning, it shall be allowed to dry naturally, and shall be kept away from direct heat. In metallic products some mechanic parts (spring, pin, hinge, etc.) can be regularly slightly lubricated to ensure better operation. Other maintenance and cleaning procedures should be adhered to detailed instructions stated in the manual of the equipment.
- personal protective equipment should be stored loosely packed, in a well-ventilated place, protected from direct light, ultraviolet degradation, damp environment, sharp edges, extreme temperatures and corrosive or aggressive substances.

IT IS THE RESPONSIBILITY OF THE USER ORGANISATION TO PROVIDE THE IDENTITY CARD AND TO FILL IN THE DETAILS REQUIRED. THE IDENTITY CARD SHOULD BE FILLED IN BEFORE THE FIRST USE BY A COMPETENT PERSON, RESPONSIBLE IN THE USER ORGANIZATION FOR PROTECTIVE EQUIPMENT. ANY INFORMATION ABOUT THE EQUIPMENT LIKE PERIODIC INSPECTIONS, REPAIRS, REASONS OF EQUIPMENT'S WITHDRAWAL FROM USE SHALL BE NOTED INTO THE IDENTITY CARD BY A COMPETENT PERSON. THE IDENTITY CARD SHOULD BE STORED DURING A WHOLE PERIOD OF EQUIPMENT UTILIZATION. DO NOT USE THE EQUIPMENT WITHOUT THE IDENTITY CARD. ALL RECORDS IN THE IDENTITY CARD CAN BE FILLED IN ONLY BY A COMPETENT PERSON.

IDENTITY CARD

MODEL AND TYPE OF EQUIPMENT	REF. NUMBER
-----------------------------	-------------

SERIAL NUMBER	DATE OF MANUF.
---------------	----------------

USER NAME

DATE OF PURCHASE	DATE OF PUTTING INTO OPERATION
------------------	--------------------------------

PERIODIC EXAMINATION AND REPAIR HISTORY					
	DATE	REASON FOR ENTRY PERIODIC EXAMINATION OR REPAIR	DEFECTS NOTED, REPAIRS CARRIED OUT AND OTHER RELEVANT INFORMATIONS	NAME AND SIGNATURE OF COMPETENT PERSON	PERIODIC EXAMINATION NEXT DUE DATE
1					
2					
3					
4					
5					
6					
7					
8					